

Installation Note

Agilent Technologies ESG Vector Signal Generator
Add Option 1E5 (High Stability Timebase)
Upgrade Kit Part Number: E4438CK-1E5



Agilent Technologies

Part Number E4400-90553
Printed in USA June 2004

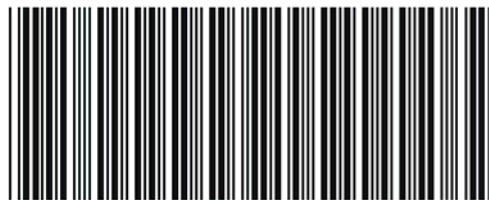

E4400-90553

Notice

The information contained in this document is subject to change without notice.

Agilent Technologies makes no warranty of any kind with regard to this material, including but not limited to, the implied warranties of merchantability and fitness for a particular purpose. Agilent Technologies shall not be liable for errors contained herein or for incidental or consequential damages in connection with the furnishing, performance, or use of this material.

Add Option 1E5 (High Stability Timebase)

Upgrade Kit Part Number: E4438CK-1E5

Product Affected:	E4438C
Serial Numbers:	All
Options:	
To Be Performed By:	(X) Agilent Technologies Service Center (X) Personnel Qualified by Agilent Technologies (X) Customer
Estimated Installation Time:	0.5 hours
Estimated Verification Time:	1.0 hours

Introduction

This upgrade kit adds the High Stability Timebase (Option 1E5) to the E4438C.

NOTE This upgrade kit is not compatible with Option UNJ or Option 506.

Installation includes the following major steps:

1. Check signal generator functionality.
2. Remove the outer and inner signal generator covers.
3. Install the A18 High Stability Reference Board.
4. Install new firmware.
5. Verify proper installation of Option 1E5.
6. Re-assemble the signal generator.
7. Attach Option 1E5 label.
8. Verify signal generator calibration.

Installation Kit Parts List

Item	Quantity	Description	Part Number
1	1	ESG-C Firmware Upgrade Kit*	E4400-60597
2	1	Option 1E5 Label*	7121-1232
3	1	A18 Reference Board	E4400-60513
4	1	Installation Note*	E4400-90553

*This item can not be ordered separately.

Tools Required

- TORX T-10 driver
- TORX T-15 driver
- TORX T-20 driver

Safety Considerations

WARNING Before you disassemble the signal generator, turn the power switch off and unplug the power cord. Failure to unplug the signal generator can result in personal injury.

CAUTION Electrostatic discharge (ESD) can damage or destroy electronic components. All work on electronic assemblies should be performed at a static-safe workstation.

Check Signal Generator Functionality

Use the following procedure to confirm that the signal generator powers up and that the internal check identifies no errors. The internal check evaluates the operation of the signal generator and returns an error message if it detects a problem.

NOTE When the signal generator is first connected to ac line power, the error message **ERROR 514, Reference Oven Cold** occurs which causes both the **OVEN COLD** annunciator and the **ERR** annunciator to turn on.

After approximately five minutes, the **OVEN COLD** annunciator automatically clears, but the **ERR** annunciator remains on until all errors are cleared from the error queue.

1. Turn on the signal generator and let it warm up for at least five minutes.
2. Run the signal generator self-test by pressing **Utility > Instrument Info/Help Mode > Self Test > Run Complete Self Test**. Upon completion a summary of the self-test will be displayed. Use the service guide to troubleshoot any failures detected by the test.

NOTE Some circuits may require up to 50 minutes to warm up before passing the self-test. If self-tests continue to fail after 50 minutes of warm up, troubleshoot the signal generator.

3. Check to see if the **ERR** annunciator is on.
 - If the **ERR** annunciator is on, review the error messages in the error queue by pressing **Utility > Error Info**. The first error message in the error queue appears in the display text area. (Refer to the signal generator error messages document for information about each error message.)

After resolving all problems causing errors, press **Clear Error Queue(s)**.
 - If the **ERR** annunciator is off, the signal generator functionality check has passed.

Remove the Outer and Inner Signal Generator Covers

Tools Required

- T-10 driver
- T-15 driver
- T-20 driver

Removing the Outer Cover

Refer to [Figure 1](#) for this procedure.

1. Disconnect the power cord.
2. Using a T-20 driver, remove the two strap handles (1) by loosening the screws.
3. Using a T-15 driver, remove the center screws (3) on the four rear-panel feet (2).
4. Remove the four bottom feet (5) and (6) from the cover by pushing and pulling the tab.
5. Slide the outer cover (4) off the frame.

Removing the Inner Covers

Refer to [Figure 1](#) for this procedure.

1. Using a T-10 driver, remove the ten screws (10) from the inner-top cover (7).
2. Remove the inner-top cover.
3. Using a T-10 driver, remove the four screws (8) from the inner-side cover (9).
4. Slide the inner side cover forward to unlock the sheet metal from the chassis.
5. Remove the inner-side cover.

Figure 1

Outer and Inner Instrument Cover Removal

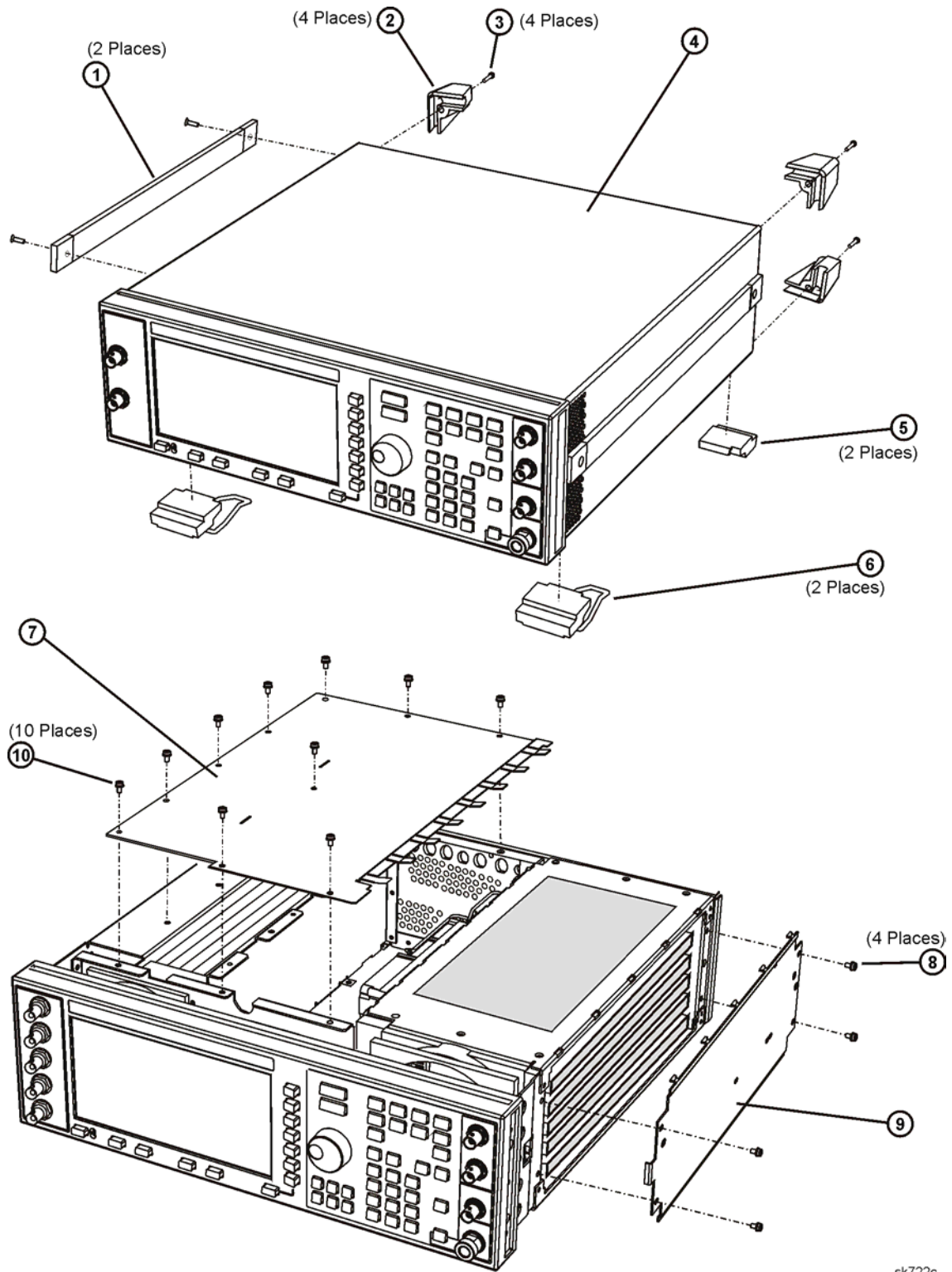

sk722c

Install the A18 High Stability Reference Board

Refer to [Figure 2](#) for this procedure.

1. Locate Side-SLOT 5.
2. Lift the retention levers and disconnect the A18 Reference board.
3. Lift the board assembly out of Side-SLOT 5.
4. Insert the new A18 Reference board, E4400-60513, included in this installation kit.

Figure 2 **A18 Reference Board**

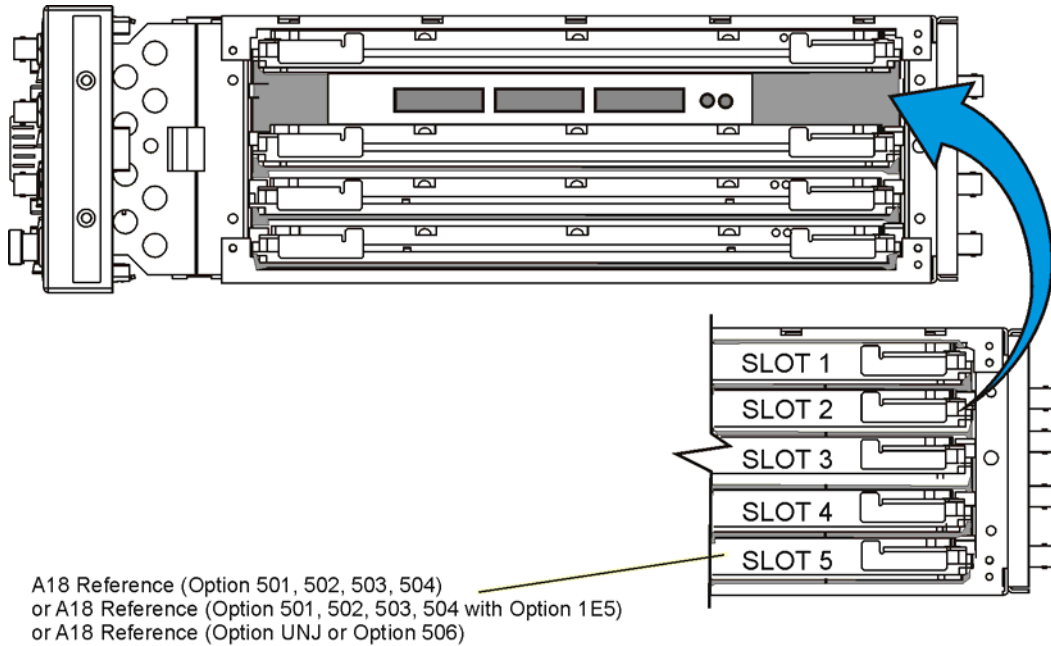

Install New Firmware

1. The firmware upgrade kit contains an installation note. Using the installation note, install the new firmware.
2. Perform the verification procedure described in the firmware upgrade installation note.

Verify Proper Installation of Option 1E5

1. Turn the signal generator on.
2. Check that Option 1E5 is installed by pressing, **Utility > Instrument Info/Help Mode > Options Info**.
3. Perform the “[Check Signal Generator Functionality](#)” procedure, as described on [page 5](#).

Re-Assembling the Instrument

Refer to [Figure 1](#).

1. Reinstall the inner and outer instrument covers by reversing the order for removal.
2. Torque all T-10 screws to 9 in-lbs.
3. Torque all T-15 and T-20 screws to 21 in-lbs.

Attach Option 1E5 Label

1. Cut out one Option 1E5 label, provided in this installation kit.
2. Attach the label to the serial tag option, located on the rear panel. This indicates that Option 1E5 is installed.

Verifying Signal Generator Calibration

1. Turn the signal generator on and allow it to warm up for 30 minutes.
2. Perform the following adjustment/performance tests to verify signal generator calibration. Refer to the Post Repair Procedures for the A18 Assembly in Chapter 4 of the ESG Vector Signal Generator Service Guide, part number E4400-90511:
 - Self Test
 - Internal FM Accuracy and Distortion
 - Internal AM Accuracy and Distortion
 - Phase Modulation Accuracy and Distortion
 - FM Frequency Response
 - AM Frequency Response
 - Phase Modulation Frequency Response
 - DCFM Frequency Offset Relative to CW
 - Residual FM
 - Harmonic, Subharmonic, and Nonharmonic Spurious
 - Timebase Aging Rate
 - Pulse Modulation On/Off Ratio
 - Burst Modulation On/Off Ratio
 - Internal Reference Oscillator Calibration
 - Analog Bus ADC Calibration
 - Internal Source Calibration
 - Timebase DAC Calibration
 - FM Scale DAC Offset Calibration
 - FM Path Offset Calibration
 - FM In-band DAC Offset Calibration
 - FM Inverting Amplifier Offset Calibration

- FM 1/2 Path Ratio Gain Calibration
- Modulation Source Relative Gain Calibration
- FM Out-of-Band Calibration
- DCFM Calibration
- External Input Peak Detector Calibration
- AM Audio Path Offset Calibration